

# ***bq2403x (bqTiny-III™) 1.5-A Single-Chip Li-Ion and Li-Pol Charge Management IC EVM***

This user's guide describes the bq2403x (bqTiny-III™) Evaluation Module. The EVM provides a convenient method for evaluating the performance of a charge management and system power solution for portable applications using the bq2403x product family. A completely designed and tested module is presented. The charger is designed to deliver up to 1.5 A of continuous current to the system or charger for one-cell Li-ion or Li-polymer applications (see the data sheet for correct device, x) using a dc power supply. The charger is programmed from the factory to deliver 1 A of charging current.

### Contents

1	Introduction .....	2
2	Considerations When Testing and Using bq2403x ICs.....	2
3	Performance Specification Summary .....	3
4	Test Summary .....	3
5	Schematic .....	7
6	Physical Layouts.....	8
7	Bill of Materials .....	13
8	References.....	14

### List of Figures

1	Test Diagram .....	4
2	bq2403x EVM Schematic.....	7
3	Top Assembly View .....	8
4	Board Layout – Top Etch Layer .....	9
5	Board Layout – Second Etch Layer .....	10
6	Board Layout – Third Etch Layer .....	11
7	Board Layout – Bottom Etch Layer .....	12

### List of Tables

1	Performance Specification Summary For bq24030/1/2/5 EVMs .....	3
2	Bill of Materials .....	13

## 1 Introduction

The bqTiny-III powers the system while independently charging the battery. This feature reduces the charge and discharge cycles on the battery, allows for proper charge termination, and allows the system to run with an absent or defective battery pack. This feature also allows for the system to instantaneously turn on from an external power source even when using a deeply discharged battery pack.

The bqTiny-III automatically selects the USB port or the ac adapter as the power source for the system. In the USB configuration, the host can select from the two preset input maximum rates of 100 mA and 500 mA. The bqTiny-III dynamically adjusts the USB charge rate based on the system load to stay within the 100-mA or 500-mA maximum rates. The AC pin can be programmed to perform like a USB input by pulling the PSEL pin low. An external resistor, RSET1, sets the magnitude of the charge current. If the charge current exceeds the available input current, the voltage on the OUT pin drops to the  $DPPM_{OUT}$  threshold or the battery voltage, whichever is higher. The charging current is reduced to what current is available ( $I_{BAT} = I_{IN} - I_{OUT}$ ).

The bqTiny-III charges the battery in three phases: conditioning, constant current, and constant voltage. Charge is terminated based on minimum current. A resistor-programmable charge timer provides a backup safety for charge termination. The bqTiny-III automatically re-starts the charge if the battery voltage falls below an internal threshold. The bqTiny-III automatically enters sleep mode when both supplies are removed (a drop to the battery voltage).

## 2 Considerations When Testing and Using bq2403x ICs

Consider the following noteworthy items while testing and using the bq2403x ICs.

There are three ICs (bq24030/1/2/5) to select from. The significant difference is the OUT pin voltage. The bq24030/1 has a LDO 6-V regulator connected the OUT pin. The intent on this charger is to provide a solution for using an inexpensive unregulated adaptor to power the charger. When unloaded, a 5-VDC adapter peak charges to ~8 V, but when loaded it quickly drops closer to 5 V. Since this is a linear regulator/charger, the higher the input voltage the lower the current level has to be to not exceed the power rating of the IC. The bq24032 has a LDO 4.4-V regulator connected to the OUT pin. The bq24035 shuts down if the input exceeds ~6.4 VDC.

The three potential sources to power the system ( $V_{OUT}$ ) are: AC (AC-to-DC adapter), USB port, and battery. The IC is designed to power the system continuously. The battery, in most cases, is the last line of backup. If the AC or USB inputs are not available (or disabled), the battery connects to the system.

In thermal regulation condition ( $T_J = 125^\circ\text{C}$ —not a first-choice design mode of operation), the charge current is reduced to the battery, and the system still gets its power from the input. The battery supplement is still available in thermal regulation if the  $V_{OUT}$  falls to  $V_{BAT}$ . In thermal cutoff (~155°C), the input sources are disconnected, but the internal battery FET connects the battery to  $V_{OUT}$ .

The battery FET only opens (when needed) if a short on the  $V_{OUT}$  pulls more than 4 A of current, or any condition has  $V_{OUT}$  less than 1 Vdc (considered a short-circuit condition). In the short-circuit condition are two types of *pullups*: a 500- $\Omega$  resistor from each input to  $V_{OUT}$  and a 10-mA current source from the battery to the  $V_{OUT}$ . The system load has to be reduced (>200  $\Omega$ ) on the output to allow  $V_{OUT}$  to rise above 1 Vdc. If the voltage on the DPPM pin is held below 1 V, then the short-circuit feature is disabled. Therefore, placing a small capacitor (~1000 pF) across the DPPM resistor delays the short-circuit protection on input powerup by a few microseconds. Typically, the system does not have much of a load below 1 V; so, powering up during a potential short-circuit condition usually is not a problem.  $V_{OUT}$  is always powered if there is any source voltage; so, dropping below 1 V is not a typical mode.

Another feature that protects system integrity is dynamic power path management (DPPM). The voltage on the DPPM pin ( $DPPM_{IN}$ ) times a scaling factor of ~1.15 is the  $DPPM_{OUT}$  voltage. The  $DPPM_{OUT}$  voltage is the critical voltage, determined by the designer, where battery charging current is reduced to keep the system voltage ( $V_{OUT}$ ) from further decay. A special feature to keep in mind is that when in DPPM mode the internal oscillator timer is slowed proportionally to how much the programmed charger current is reduced. This allows the timers (safety and others) to be appropriately adjusted during operation. Therefore, when performing any test where time is measured, keep in mind this adjustment factor.

Another critical feature is power handoff. The power handoff is initiated autonomously or by request. The PSEL (High/Low) sets which input source takes priority (AC or USB). This handoff happens immediately on request. The CE pin (going high) immediately enables the chip; disabling it (going low) delays handoff for 5 ms. For autonomous power selection (e.g., the selected source is lost), the IC switches sources when the Power Good (PG) status indicates the primary selected source is no longer good. PG is defined as  $>(V_{BAT} + 80 \text{ mV})$ . This means that if the battery is dead (missing, or discharged below a useable system voltage), the IC switches over to the other available source when the  $V_{OUT}$  reaches the *dead battery* voltage. This design feature prevents cycling between a stronger current-limiting source and the USB source. In most situations, if AC power is available (prior to losing it), the battery probably would not be discharged.

### 3 Performance Specification Summary

Table 1 summarizes the performance specifications of the EVM.

**Table 1. Performance Specification Summary For bq24030/1/2/5 EVMs**

SPECIFICATION	TEST CONDITIONS	MIN	TYP	MAX	UNITS
Input DC Voltage, $V_{I(AC)}$		4.8 V	5.0	6.5	Volts
Input DC USB Voltage, $V_{I(USB)}$			5.0		
Battery Charge Current, $I_{O(CHG)}$			1.0	2.0+	Amperes
Power Dissipation, bq2403x IC, 1 Cell	$P_{diss} = (V_{in} - V_{out})I_{out} + (V_{in} - V_{bat})I_{bat} + (V_{in} - V_{ldo})I_{LDO}$			see <sup>(1)</sup>	Watts

(1) The HPA073 (bq2403x) thermal design is optimized (8+ vias, 0.031-inch PWB, 2 oz. copper) to give  $\theta_{JA} \sim 27^\circ\text{C/W}$ .

### 4 Test Summary

This section covers the setup and tests performed in evaluating the EVM.

#### 4.1 Equipment

- Power supply (+5.25  $\pm$  0.25 VDC), current limit set to 2.0 A  $\pm$  0.2 A for AC input to the UUT
- USB high-power port (500 mA) and cable (J1 is an alternate USB connection)
- Three Fluke 75 DMMs (equivalent or better)
- Oscilloscope, Model TDS220 (equivalent or better)

#### 4.2 Equipment Setup

- Preset the UUT power supply voltage and current prior to connection to UUT; turn off the power supply and connect the supply to J2-AC/GND (+ to AC and – to GND).
- Connect a 10- $\Omega$  load to J7-OUT/GND.
- Connect a 1k- $\Omega$  load to J5-LDO/GND.
- Connect a fully discharged (< 2.8-VDC) single-cell Li-ion or Li-polymer battery to J8-BAT+/BAT–.
- Connect the DMMs as shown in Figure 1.

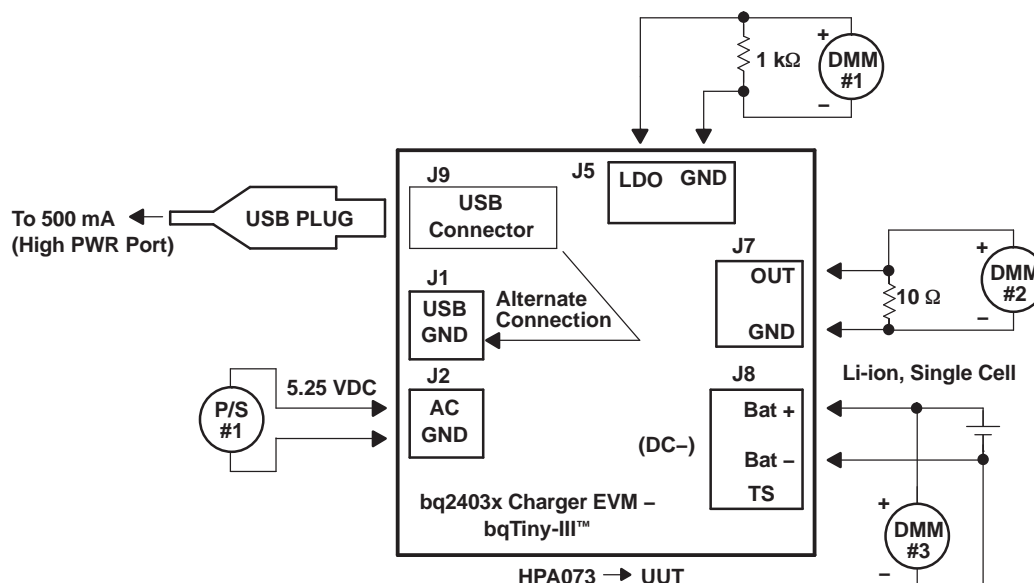
**Figure 1. Test Diagram**

### 4.3 Test Procedure

1. Verify that the equipment is set up according to Equipment Setup section.
2. Set jumpers on the UUT as follows: JMP1-0.5; JMP2-AC; JMP3-EN; set JMP4 through JMP7 to LED.
3. Adjust  $R_{DPPM}$  until TP1 is  $31\text{ k}\Omega \pm 0.1\text{ k}\Omega$  with respect to GND, and adjust  $R_{TMR}$  until TP2 is  $50\text{ k}\Omega$  with respect to GND.
4. Verify that  $V_{OUT}$  is approximately equal to  $V_{BAT}$  (if  $V_{out} < 1.1\text{ V}$ , the output is in short-circuit mode. To get out of this mode, momentarily disconnect the  $10\text{-}\Omega$  load, or touch a  $1\text{-}\mu\text{F}$  capacitor between the DPPM pin and ground).
5. Power up the **+5.25-VDC Supply** to the UUT.
6. Verify  $V_{BAT}$  is between 2.4 VDC and 3.0 VDC, and the charger is in pre-charge state: LEDs STAT1 (D2), STAT2 (D3), and ACPG (D5) are on.  
If  $V_{BAT}$  is above the low-voltage threshold ( $V_{(LOWV)} \sim 3\text{ V}$ ), then the IC is in fast-charge mode (STAT2 (D3) is off (High)). If the IC is in fast charge, skip step 10.
7. Verify  $I_{BAT}$  is  $\sim 0.1\text{ A}$  ( $I_{BAT} \sim I_{AC} - (V_{OUT} / R_{OUT}) - 0.01\text{ A}$ )
8. Verify  $V_{OUT}$  is between 4.3 VDC and 4.5 VDC for the bq24032 IC. The bq24030/1/5 switches the input to the output for  $V_{AC}$  less than 6 V. The bq24030/1 regulates  $V_{OUT}$  to 6 V for larger inputs, and the bq24035 turns off the charging and output for an AC input above 6 VDC.
9. Verify  $V_{LDO}$  is between 3.2 VDC and 3.4 VDC.
10. Allow the battery to charge until  $V_{BAT}$  is between 3.2 VDC and 4.0 VDC. The charger should deliver the programmed constant current to the battery unless the input cannot source the required current.
11. Verify **D3** (STAT2) has turned off.
12. Verify  $I_{BAT}$  is  $\sim 1.0\text{ A}$  (for a  $10\text{-k}\Omega$  resistor on  $ISET1$ ,  $I_{BAT} \sim I_{AC} - (V_{OUT} / R_{OUT}) - 0.01\text{ A}$ ).
13. Verify  $I_{AC}$  is  $\sim 1.5\text{ A}$  (for  $10\text{-}\Omega$  **OUT** load and  $10\text{ k}\Omega$  on **ISET1**).
14. Apply a short between J3-4 (CE) and J3-3 (GND) on the UUT. This overrides the JMP3  $100\text{-k}\Omega$  pullup, disables the charging, puts the IC in low power mode and connects the battery to the OUT pin. Note that if CE is floated (JMP3 is removed and J3-4 connection is removed) the IC may bounce between the charging and disabled states. Verify on the scope that  $V_{OUT}$  does not drop out. Note that the transition between power sources is implemented by break-before-make switching and requires the capacitance on  $V_{OUT}$  to be able to hold up the system voltage for at least  $50\text{ }\mu\text{s}$ .
15. Verify **D2** (STAT1) has turned off.
16. Verify  $I_{AC}$  drops below 10 mA (should be  $< 200\text{ }\mu\text{A}$  into the IC if ACPG LED (current) JMP6 is removed).

17. Verify  $V_{OUT}$  is within  $-50$  mV of  $V_{BAT}$ .
18. Remove short between J3-4 and J3-3 on UUT. Verify on the scope that  $V_{OUT}$  does not drop out. Verify **D2** (STAT1) has turned on, charging has resumed and  $V_{OUT}$  is powered from the input.
19. Disconnect the **+5.25-VDC Input Supply** from the UUT AC input. Verify on the scope that  $V_{OUT}$  does not drop out. Verify  $V_{OUT}$  is within  $-50$  mV of  $V_{BAT}$  and **D2** (STAT1) and **D5** (ACPG) LEDs turn off. This demonstrates battery power backup for loss of AC adapter.
20. Reapply the +5.25-VDC supply to the UUT AC input. Verify on the scope that  $V_{OUT}$  does not drop out. Verify **D2** (STAT1) and **D5** (ACPG) LEDs turn on.
21. Adjust R15 until the voltage on TP1 is  $\sim 3.50$  VDC ( $V_{BAT}$  should be less than 3.9 V for this demonstration; otherwise, discharge battery).
22. Reduce the current limit on the input supply to  $\sim 1$  A (going to AC pin on UUT) and verify on the scope that  $V_{OUT}$  has dropped to the VDPPM level of  $\sim 4.0$  V  $\{(3.5 \text{ V at TP1}) \times 1.15 = 4 \text{ V}\}$ . Note that the current into the battery is  $\sim 600$  mA (1-A input minus 400 mA to the system), which has been reduced to keep the output from falling below the programmed DPPM OUTPUT threshold of 4 V. This demonstrates DPPM operation (charging current to the battery is reduced if output drops to the DPPM OUTPUT voltage threshold attempting to keep the output voltage from dropping further).
23. Further reduce the input's current limit to 250 mA. Verify on the scope that  $V_{OUT}$  does not drop out. Verify that  $V_{OUT}$  drops just below  $V_{BAT}$  ( $< 50$  mV). Because the available input current is less than the system **OUT** load, reducing the battery charging current to zero is still not enough reduction in load to keep the output from dropping. Once the output drops below  $\sim 50$  mV, the internal battery FET turns on and allows the battery to source the OUT pin system load. This demonstrates battery supplement mode.
24. Return the current limit of the +5.25-V supply to  $\sim 2$  A. Verify  $V_{OUT}$  returns to Vreg or Vin (see Step 8 of this test procedure).
25. Set JMP2 (PSEL) to USB (PSEL = low). Verify that the input current (AC) drops to between 400 mA and 500 mA. The programmed charge current of  $\sim 1$  A and the system load of  $10 \Omega$  exceeds the USB 0.5-A limit; therefore,  $V_{OUT}$  drops until the DPPM OUTPUT voltage threshold, or battery voltage, is reached (which ever is higher). If the DPPM OUTPUT threshold is larger, the charging current is reduced to keep the output voltage from dropping further. If the battery voltage is higher, the battery supplements the current to keep the output from dropping too much (50 mV to 200 mV) below the battery voltage. Note that setting PSEL to low (USB mode; PSEL high is AC mode) selects the USB input as the primary source. If the USB source is not present, and the ac source is present, the IC uses the AC input source as if it were a USB input. This feature is useful if only one input power connector is desired, and two sources (USB and AC adaptor) are available. A *keyed* cable or a u-controller would set the PSEL pin for the available source. Note that the system would ideally go to a lower power mode prior to selecting USB operation to avoid pulling down  $V_{OUT}$ .
26. Plug in a USB cable from a high-power port (500 mA) into the UUT (or supply 5 VDC to J1). Verify that the USB input now supplies the input current instead of the AC (J2) input. This demonstrates that JMP2 (PSEL) defines the priority of the inputs. If PSEL = Low (USB priority), then the USB input is used first, if available, and if not it switches to AC power at USB-current levels.
27. Verify that **D4** (USBPG) turns on.
28. Set JMP2 (PSEL) to AC, and verify that the AC supply is providing  $\sim 1.5$  A of current ( $\sim 0.44$  to the load and 1 A to the battery plus miscellaneous).
29. Remove the ac-input supply and verify that the USB source is supplying between 400 mA and 500 mA of current to the input. The output should have dropped to the DPPM OUTPUT threshold or battery voltage (whichever is higher).
30. Verify that **D5** (ACPG) turns off.
31. Reapply the AC-input source and verify that the AC source is now providing the  $\sim 1.5$  A as before.
32. Verify that **D5** (ACPG) turns on.
33. Set JMP2 (PSEL) to USB, and verify that the USB source is now providing between 400 mA and 500 mA of current.
34. Set JMP1 to 0.1 on the UUT. Verify that the input current has dropped below 100 mA and  $V_{OUT}$  has dropped slightly below  $V_{BAT}$ . In this test, the system load is  $10 \Omega$ , which would result in the output dropping to 1 V at 100 mA if there were no other source to help out. As the output voltage drops to the DPPM OUTPUT threshold, the charging current is reduced to zero, but  $V_{OUT}$  continues to drop until it reaches the battery voltage. The internal battery FET turns on to supplement the OUTPUT. This

## Test Summary

---

- demonstrates battery supplement mode because the system load exceeds the available input current.
35. Disconnect the USB source and verify that the AC source takes over in USB mode at the 100-mA charge level.
  36. Verify that **D4** (USBPG) turns off.
  37. Set JMP2 to AC (PSEL = High). Skip to next step for HPA073-1/3 (bq24030/1/5 ICs). Verify that the (AC) input current is ~1 A. Verify that IBAT is reduced to half the programmed level, ~0.5 A. This is the AC half-charge mode and is implemented on bq24032 when ISET2 is low (0.1 A) and J2-PSEL is AC (High).
  38. Set JMP1 to 0.5. Continue to let the battery charge. Note that once the battery voltage reaches regulation (~4.20 VDC for bq24030/2/5 and 4.1 VDC for bq24031) the charging current tapers off.
  39. Verify that the charging terminates when the battery current tapers to C/10 or 100 mA (1 A/10, programmed charge current divided by 10). Verify D2 (STAT1) turns off (High) and D3 (STAT2) turns on (Low).
  40. If a load is applied across the battery such that the battery is discharged to ~100 mV below the regulation voltage, the charger starts a new charging cycle.

This concludes the evaluation of the bq2403x EVM. Several more features implemented in the IC are not demonstrated in this user's guide. See the data sheet to learn more about thermal regulation, thermal cutoff, USB boot up, and short-circuit protection.

5 Schematic

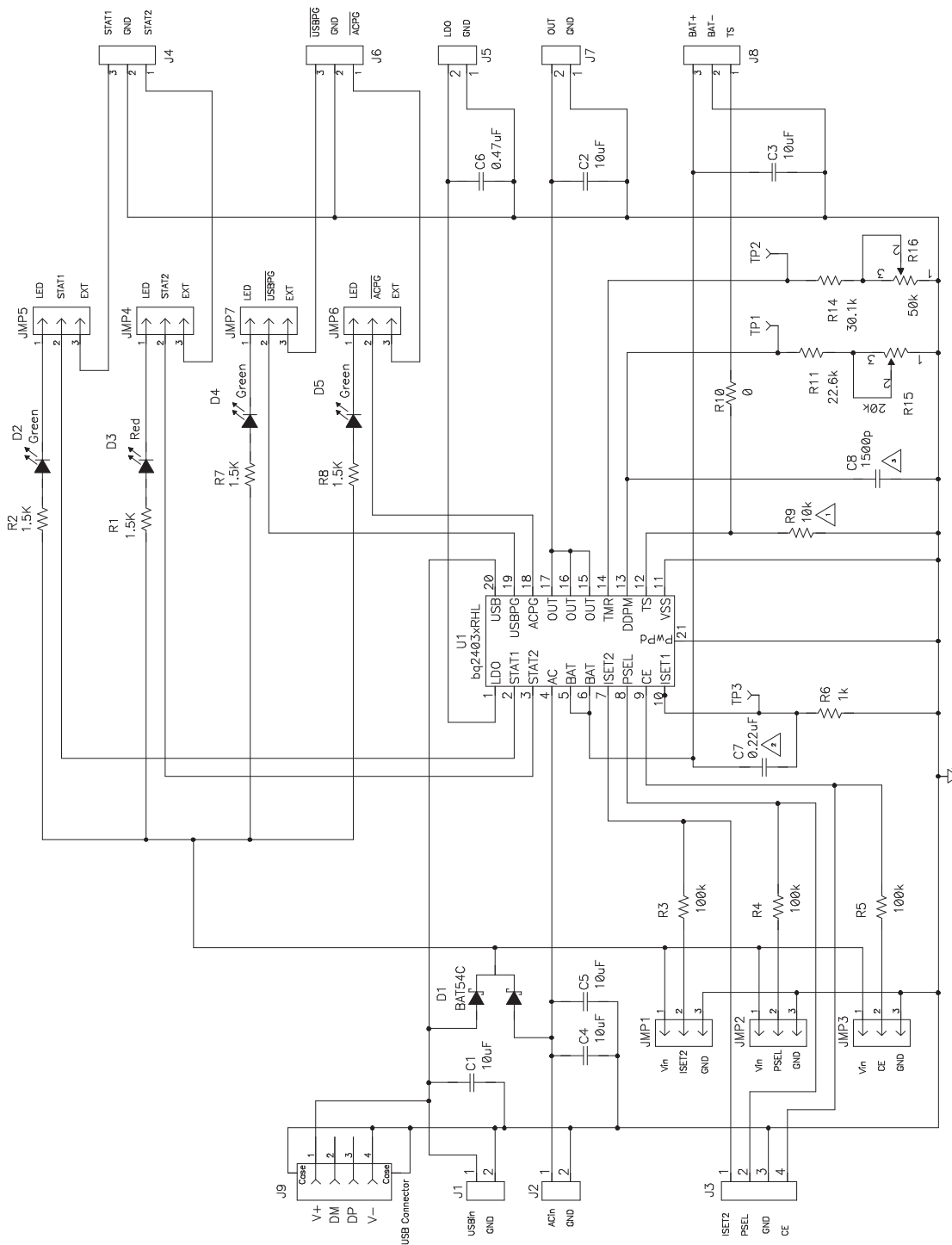

Figure 2. bq2403x EVM Schematic



## 6 Physical Layouts

This section contains the board layout and assembly drawings for the EVM.

### 6.1 Board Layout

Figure 3 shows the top assembly view of the EVM. Figure 4 shows the top etch layer of the EVM. Figure 5 shows the board second etch layer of the EVM. Figure 6 shows the board third etch layer of the EVM. Figure 7 shows the bottom etch layer of the EVM.

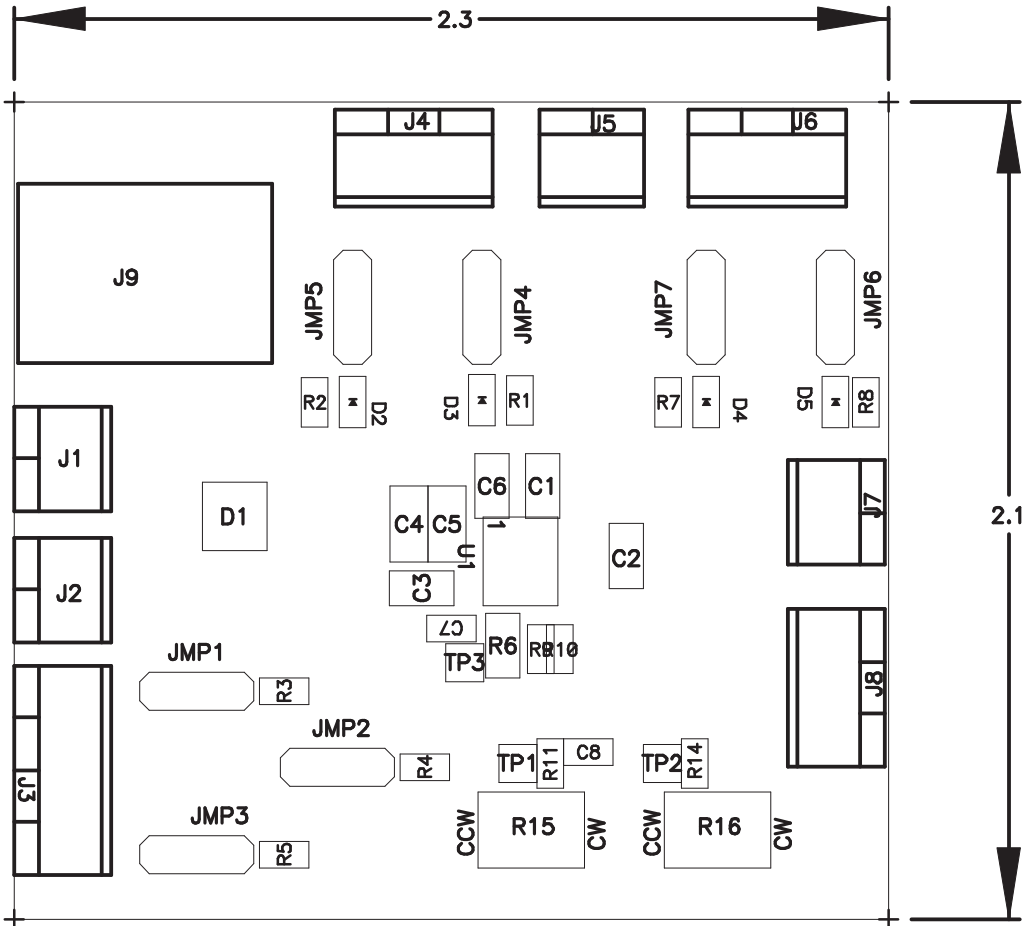

Figure 3. Top Assembly View



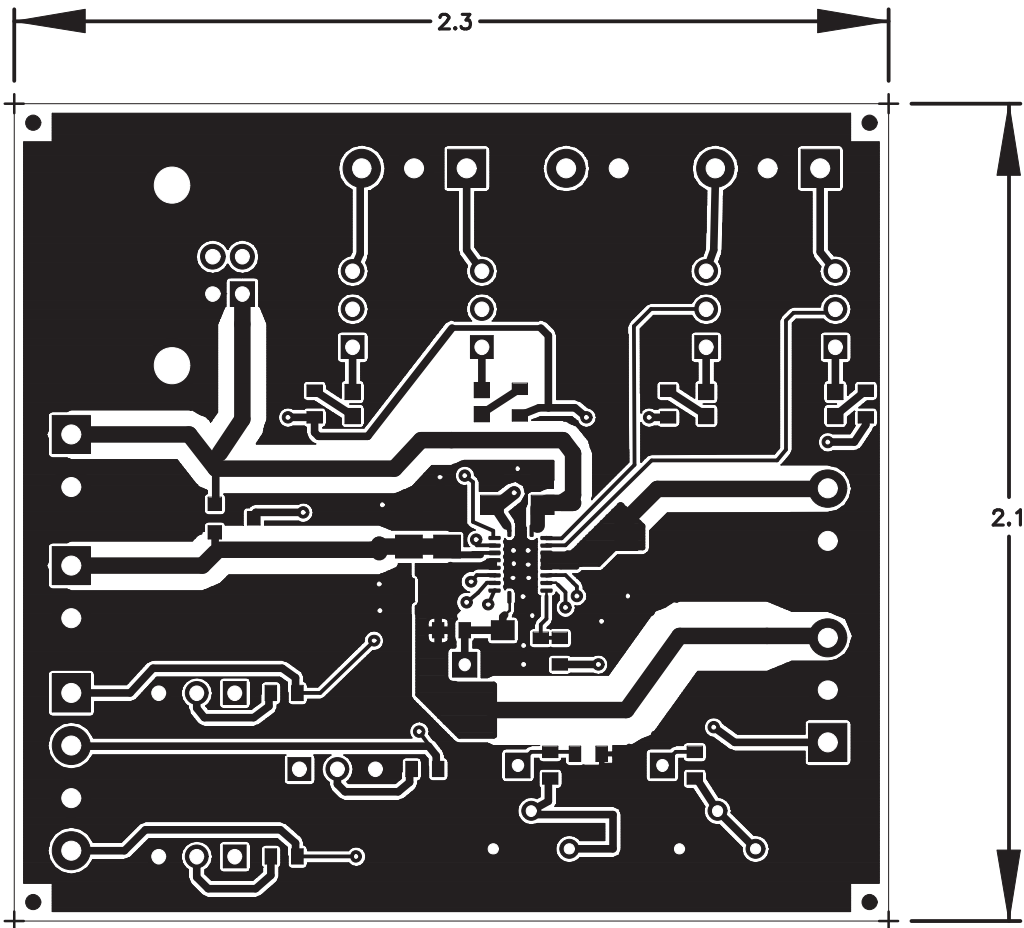

Figure 4. Board Layout – Top Etch Layer

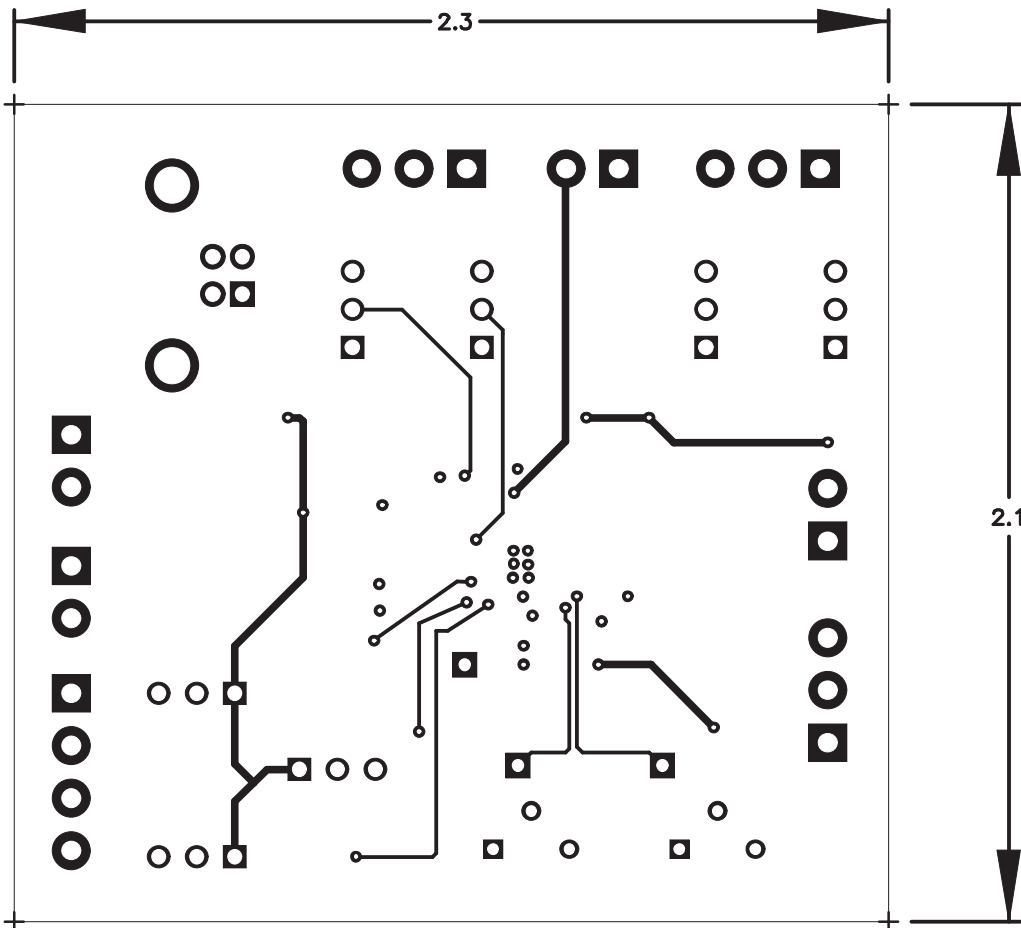

Figure 5. Board Layout – Second Etch Layer

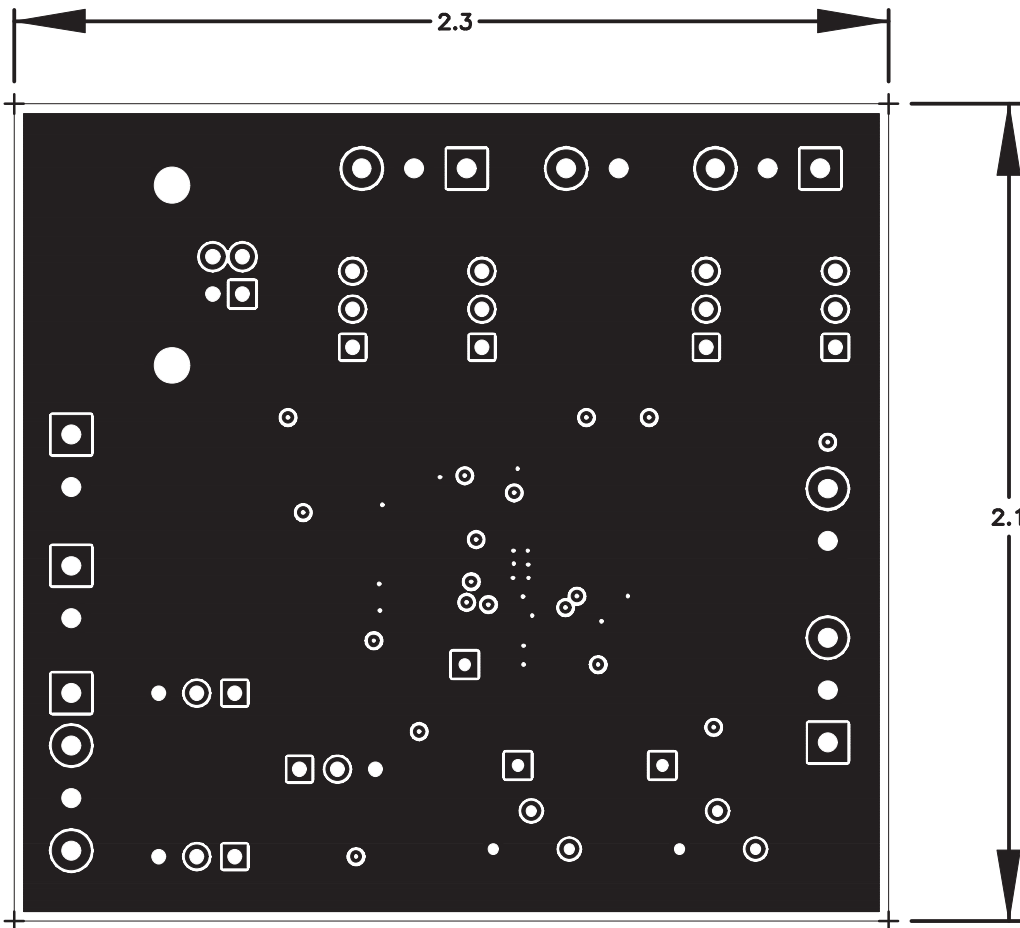

Figure 6. Board Layout – Third Etch Layer

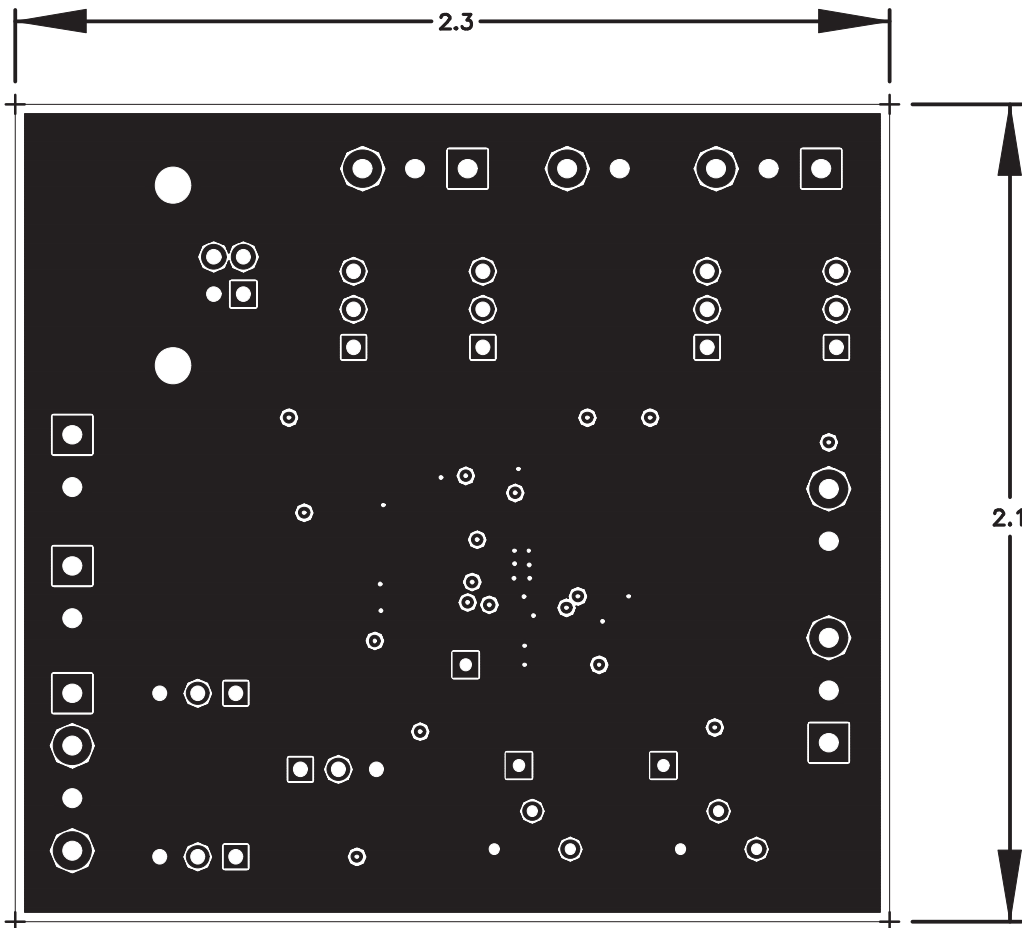

Figure 7. Board Layout – Bottom Etch Layer

**7 Bill of Materials**
**Table 2. Bill of Materials<sup>(1)(2)(3)(4)</sup>**

COUNT				REFDES	DESCRIPTION	SIZE	MFR	PART NUMBER
bq24030-001	bq24032-002	bq24035-003	bq24031-004					
3	3	3	3	C1, C2, C3	Capacitor, ceramic, 10- $\mu$ F, 6.3-V, X5R, 20%	805	Panasonic	ECJ-2FB0J106M
2	2	2	2	C4, C5	Capacitor, ceramic, 10- $\mu$ F, 25-V, X5R, 20%	1206	Panasonic	ECJ-3YB1E106M
1	1	1	1	C6	Capacitor, ceramic, 0.47- $\mu$ F, 16-V, X7R, 10%	805	Panasonic	ECJ-2YB1C474K
0	0	0	0	C7	Capacitor, ceramic, 0.22- $\mu$ F, 10-V, X5R, 10%	603	Panasonic	ECJ-1VB1A224K
0	0	0	0	C8	Capacitor, ceramic, xxx- $\mu$ F, 10-V, X5R, 10%	603	Panasonic	ECJ-1VB1C103K
1	1	1	1	D1	Diode, dual Schottky, 200-mA, 30-V	SOT23	Vishay-Liteon	BAT54C
3	3	3	3	D2, D4, D5	Diode, LED, green, 2.1-V, 20-mA, 6-mcd	603	Liteon	160-1183-1-ND
1	1	1	1	D3	Diode, LED, red, 1.8-V, 20-mA, 20-mcd	603	Liteon	160-1181-1-ND
4	4	4	4	J1, J2, J5, J7	Terminal block, 2-pin, 6-A, 3.5 mm	0.27 x 0.25	OST	ED1514
1	1	1	1	J3	Terminal block, 4-pin, 6-A, 3.5 mm	0.55 x 0.25	OST	ED1516
3	3	3	3	J4, J6, J8	Terminal block, 3-pin, 6-A, 3.5 mm	0.41 x 0.25	OST	ED1515
1	1	1	1	J9	Connector, USB upstream (Type B)	0.47 x 0.67	Molex	67068-1000
7	7	7	7	JMP1, JMP2, JMP3, JMP4, JMP5, JMP6, JMP7	Header, 3-pin, 100-mil spacing, (36-pin strip)	0.10 x 3	Sullins	PTC36SAAN
4	4	4	4	R1, R2, R7, R8	Resistor, Chip, 1.5-k $\Omega$ , 1/16-W, 1%	603	Std	Std
1	1	1	1	R10	Resistor, Chip, 0- $\Omega$ , 1/16-W, 1%	603	Std	Std
1	1	1	1	R11	Resistor, Chip, 22.6-k $\Omega$ , 1/16-W, 1%	603	Std	Std
1	1	1	1	R14	Resistor, Chip, 30.1-k $\Omega$ , 1/16-W, 1%	603	Std	Std
1	1	1	1	R15	Potentiometer, 20-k $\Omega$ , 1/4 inch Cermet, 12-turn, top-adjust	0.25 x 0.17	Bourns	3266W-203
1	1	1	1	R16	Potentiometer, 50-k $\Omega$ , 1/4 inch Cermet, 12-turn, top-adjust	0.25 x 0.17	Bourns	3266W-503
3	3	3	3	R3, R4, R5	Resistor, chip, 100-k $\Omega$ , 1/16-W, 1%	603	Std	Std
1	1	1	1	R6	Resistor, chip, 1-k $\Omega$ , 1/10W, 1%	805	Std	Std
1	1	1	1	R9	Resistor, chip, 10-k $\Omega$ , 1/16-W, 1%	603	Std	Std
3	3	3	3	TP1, TP2, TP3	Test point, 0.032-inch hole		None	Void
1			1	U1	IC, single chip charge and power path management	QFN	TI	bq24030RHL
	1			U1	IC, single chip charge and power path management	QFN	TI	bq24032ARHL
		1		U1	IC, single chip charge and power path management	QFN	TI	bq24035RHL
1	1	1	1	--	PCB, 2-inch x 2-inch x 0.31-inch		Any	HPA073

- (1) These assemblies are ESD sensitive, ESD precautions shall be observed.
- (2) These assemblies must be clean and free from flux and all contaminants. Use of no-clean flux is not acceptable.
- (3) These assemblies must comply with workmanship standards IPC-A-610 Class 2.
- (4) Reference designators marked with an asterisk (\*\*\*) cannot be substituted. All other components can be substituted with equivalent MFR's components.

## 8 References

1. [SLUS618](#), bq2403x Datasheet

### FCC Warning

This evaluation board/kit is intended for use for **ENGINEERING DEVELOPMENT, DEMONSTRATION, OR EVALUATION PURPOSES ONLY** and is not considered by TI to be a finished end-product fit for general customer use. It generates, uses, and can radiate radio frequency energy and has not been tested for compliance with the limits of computing devices pursuant to part 15 of FCC rules, which are designed to provide reasonable protection against radio frequency interference. Operation of this equipment in other environments may cause interference with radio communications, in which case the user at his own expense will be required to take whatever measures may be required to correct this interference.

### EVALUATION BOARD/KIT IMPORTANT NOTICE

Texas Instruments (TI) provides the enclosed product(s) under the following conditions:

This evaluation board/kit is intended for use for **ENGINEERING DEVELOPMENT, DEMONSTRATION, OR EVALUATION PURPOSES ONLY** and is not considered by TI to be a finished end-product fit for general consumer use. Persons handling the product(s) must have electronics training and observe good engineering practice standards. As such, the goods being provided are not intended to be complete in terms of required design-, marketing-, and/or manufacturing-related protective considerations, including product safety and environmental measures typically found in end products that incorporate such semiconductor components or circuit boards. This evaluation board/kit does not fall within the scope of the European Union directives regarding electromagnetic compatibility, restricted substances (RoHS), recycling (WEEE), FCC, CE or UL, and therefore may not meet the technical requirements of these directives or other related directives.

Should this evaluation board/kit not meet the specifications indicated in the User's Guide, the board/kit may be returned within 30 days from the date of delivery for a full refund. **THE FOREGOING WARRANTY IS THE EXCLUSIVE WARRANTY MADE BY SELLER TO BUYER AND IS IN LIEU OF ALL OTHER WARRANTIES, EXPRESSED, IMPLIED, OR STATUTORY, INCLUDING ANY WARRANTY OF MERCHANTABILITY OR FITNESS FOR ANY PARTICULAR PURPOSE.**

The user assumes all responsibility and liability for proper and safe handling of the goods. Further, the user indemnifies TI from all claims arising from the handling or use of the goods. Due to the open construction of the product, it is the user's responsibility to take any and all appropriate precautions with regard to electrostatic discharge.

**EXCEPT TO THE EXTENT OF THE INDEMNITY SET FORTH ABOVE, NEITHER PARTY SHALL BE LIABLE TO THE OTHER FOR ANY INDIRECT, SPECIAL, INCIDENTAL, OR CONSEQUENTIAL DAMAGES.**

TI currently deals with a variety of customers for products, and therefore our arrangement with the user **is not exclusive.**

TI assumes **no liability for applications assistance, customer product design, software performance, or infringement of patents or services described herein.**

Please read the User's Guide and, specifically, the Warnings and Restrictions notice in the User's Guide prior to handling the product. This notice contains important safety information about temperatures and voltages. For additional information on TI's environmental and/or safety programs, please contact the TI application engineer or visit [www.ti.com/esh](http://www.ti.com/esh).

No license is granted under any patent right or other intellectual property right of TI covering or relating to any machine, process, or combination in which such TI products or services might be or are used.



### FCC Warning

This evaluation board/kit is intended for use for **ENGINEERING DEVELOPMENT, DEMONSTRATION, OR EVALUATION PURPOSES ONLY** and is not considered by TI to be a finished end-product fit for general consumer use. It generates, uses, and can radiate radio frequency energy and has not been tested for compliance with the limits of computing devices pursuant to part 15 of FCC rules, which are designed to provide reasonable protection against radio frequency interference. Operation of this equipment in other environments may cause interference with radio communications, in which case the user at his own expense will be required to take whatever measures may be required to correct this interference.

Mailing Address: Texas Instruments, Post Office Box 655303, Dallas, Texas 75265  
Copyright © 2007, Texas Instruments Incorporated

### EVM WARNINGS AND RESTRICTIONS

It is important to operate this EVM within the input voltage range of 0 V to 6.5 V and the output voltage range of 0 V to 6.5 V.

Exceeding the specified input range may cause unexpected operation and/or irreversible damage to the EVM. If there are questions concerning the input range, please contact a TI field representative prior to connecting the input power.

Applying loads outside of the specified output range may result in unintended operation and/or possible permanent damage to the EVM. Please consult the EVM User's Guide prior to connecting any load to the EVM output. If there is uncertainty as to the load specification, please contact a TI field representative.

During normal operation, some circuit components may have case temperatures greater than 85°C. The EVM is designed to operate properly with certain components above 60°C as long as the input and output ranges are maintained. These components include but are not limited to linear regulators, switching transistors, pass transistors, and current sense resistors. These types of devices can be identified using the EVM schematic located in the EVM User's Guide. When placing measurement probes near these devices during operation, please be aware that these devices may be very warm to the touch.

Mailing Address: Texas Instruments, Post Office Box 655303, Dallas, Texas 75265  
Copyright © 2007, Texas Instruments Incorporated

## IMPORTANT NOTICE

Texas Instruments Incorporated and its subsidiaries (TI) reserve the right to make corrections, modifications, enhancements, improvements, and other changes to its products and services at any time and to discontinue any product or service without notice. Customers should obtain the latest relevant information before placing orders and should verify that such information is current and complete. All products are sold subject to TI's terms and conditions of sale supplied at the time of order acknowledgment.

TI warrants performance of its hardware products to the specifications applicable at the time of sale in accordance with TI's standard warranty. Testing and other quality control techniques are used to the extent TI deems necessary to support this warranty. Except where mandated by government requirements, testing of all parameters of each product is not necessarily performed.

TI assumes no liability for applications assistance or customer product design. Customers are responsible for their products and applications using TI components. To minimize the risks associated with customer products and applications, customers should provide adequate design and operating safeguards.

TI does not warrant or represent that any license, either express or implied, is granted under any TI patent right, copyright, mask work right, or other TI intellectual property right relating to any combination, machine, or process in which TI products or services are used. Information published by TI regarding third-party products or services does not constitute a license from TI to use such products or services or a warranty or endorsement thereof. Use of such information may require a license from a third party under the patents or other intellectual property of the third party, or a license from TI under the patents or other intellectual property of TI.

Reproduction of information in TI data books or data sheets is permissible only if reproduction is without alteration and is accompanied by all associated warranties, conditions, limitations, and notices. Reproduction of this information with alteration is an unfair and deceptive business practice. TI is not responsible or liable for such altered documentation.

Resale of TI products or services with statements different from or beyond the parameters stated by TI for that product or service voids all express and any implied warranties for the associated TI product or service and is an unfair and deceptive business practice. TI is not responsible or liable for any such statements.

TI products are not authorized for use in safety-critical applications (such as life support) where a failure of the TI product would reasonably be expected to cause severe personal injury or death, unless officers of the parties have executed an agreement specifically governing such use. Buyers represent that they have all necessary expertise in the safety and regulatory ramifications of their applications, and acknowledge and agree that they are solely responsible for all legal, regulatory and safety-related requirements concerning their products and any use of TI products in such safety-critical applications, notwithstanding any applications-related information or support that may be provided by TI. Further, Buyers must fully indemnify TI and its representatives against any damages arising out of the use of TI products in such safety-critical applications.

TI products are neither designed nor intended for use in military/aerospace applications or environments unless the TI products are specifically designated by TI as military-grade or "enhanced plastic." Only products designated by TI as military-grade meet military specifications. Buyers acknowledge and agree that any such use of TI products which TI has not designated as military-grade is solely at the Buyer's risk, and that they are solely responsible for compliance with all legal and regulatory requirements in connection with such use.

TI products are neither designed nor intended for use in automotive applications or environments unless the specific TI products are designated by TI as compliant with ISO/TS 16949 requirements. Buyers acknowledge and agree that, if they use any non-designated products in automotive applications, TI will not be responsible for any failure to meet such requirements.

Following are URLs where you can obtain information on other Texas Instruments products and application solutions:

<b>Products</b>		<b>Applications</b>	
Amplifiers	<a href="http://amplifier.ti.com">amplifier.ti.com</a>	Audio	<a href="http://www.ti.com/audio">www.ti.com/audio</a>
Data Converters	<a href="http://dataconverter.ti.com">dataconverter.ti.com</a>	Automotive	<a href="http://www.ti.com/automotive">www.ti.com/automotive</a>
DSP	<a href="http://dsp.ti.com">dsp.ti.com</a>	Broadband	<a href="http://www.ti.com/broadband">www.ti.com/broadband</a>
Interface	<a href="http://interface.ti.com">interface.ti.com</a>	Digital Control	<a href="http://www.ti.com/digitalcontrol">www.ti.com/digitalcontrol</a>
Logic	<a href="http://logic.ti.com">logic.ti.com</a>	Military	<a href="http://www.ti.com/military">www.ti.com/military</a>
Power Mgmt	<a href="http://power.ti.com">power.ti.com</a>	Optical Networking	<a href="http://www.ti.com/opticalnetwork">www.ti.com/opticalnetwork</a>
Microcontrollers	<a href="http://microcontroller.ti.com">microcontroller.ti.com</a>	Security	<a href="http://www.ti.com/security">www.ti.com/security</a>
RFID	<a href="http://www.ti-rfid.com">www.ti-rfid.com</a>	Telephony	<a href="http://www.ti.com/telephony">www.ti.com/telephony</a>
Low Power Wireless	<a href="http://www.ti.com/lpw">www.ti.com/lpw</a>	Video & Imaging	<a href="http://www.ti.com/video">www.ti.com/video</a>
		Wireless	<a href="http://www.ti.com/wireless">www.ti.com/wireless</a>

Mailing Address: Texas Instruments, Post Office Box 655303, Dallas, Texas 75265  
Copyright © 2007, Texas Instruments Incorporated